

H1 Series Inverter USER MANUAL



www.chinafolinn.com



NO.1 Product introduction

1. 1 Technical Features

Items	Description
input	Rated voltage /frequency: 3ph: 380V~440V , 50Hz/60Hz 1ph: 200V~240V , 50Hz/60Hz
Allowed voltage	3ph: 320V~460V ; 1ph: 180V~260V ; voltage imbalance rate: <3% ; frequency: ±5%
output	Voltage: 0~rated input voltage Frequency: 0Hz~1000Hz
Overload capacity	150% rated current 60s, 180% rated current 2s
control performance	Control mode: V/F、SVC Modulation Mode: SVPMW Motor type: asynchronous motor, synchronous motor, single phase motor (consult factory before using) Start torque: 1Hz/150% Speed range: 1:100(SVC) Frequency accuracy: digital setting: maximum frequency±0.01%; analog setting: maximum frequency±1%; Frequency resolution: digital setting: 0.1Hz; analog setting: maximum frequency±1%; Acceleration/ deceleration curve: line/ S-curve Rapid current limit: limit current rapidly within the current protection value, to ensure the safety of the equipment None-stop when instantaneous power off: none-stop when instantaneous power off, automatic frequency drop
Operation function	Command source: keypad, terminal, communication Set value source: digital, analog, multi-speed, communication PID: support main setting+PID
Operation panel	LED display: Can display: output frequency, output voltage, output current, Bus voltage, display value 1, display value 2, error, alarm External keypad: YES
Protection function	over-current protection, over-voltage protection, under-voltage protection, overheating protection, over-load protection, phase lose protection, earth leakage, etc
Environment	Store environment: indoor, away from direct sunlight, no dust, no corrosive gas, no inflammable gas, no oil mist, no vapour, no drip and no salinity, etc Altitude: derating use above 1000M, derating 10% per 1000M Environment temperature: -10℃~+40℃(environment temperature around 40℃~50℃please derating use) Humidity: 5%~95%RH, no condensation Store temperature: -40℃~+70℃ Vibration: <5.9M/S (0.6g)

1.2 H1 nameplate

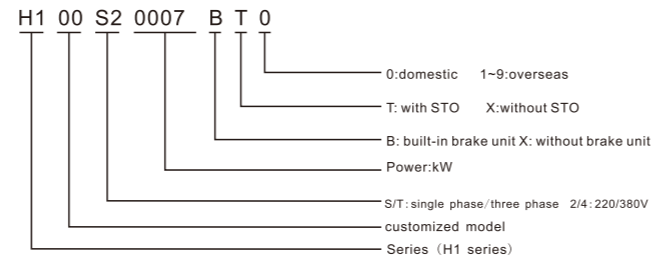

1.3 H1 series specifications and models

Base.No	Models	Input voltage	input current	Power (kw)	output current	Adaptive motor(kW)
F1	H100S20007BX0	1 phase 220V	8.2	0.75	5.0	0.75
	H100S20015BX0	1 phase 220V	14.0	1.5	7.0	1.5
F2	H100T20022BX0	1 phase 220V	23.0	2.2	12.5	2.2
		3 phase 220V	13.5			
F3	H100T20037BX0	1 phase 220V	38.6	3.7	15.2	3.7
		3 phase 220V	16.5			
F4	H100T20055BX0	3 phase 220V	24	5.5	23	5.5
	H100T20110BX0	3 phase 220V	52	11	45	11
F1	H100T40007BX0	3 phase 380V	4.0	0.75	3.0	0.75
	H100T40015BX0	3 phase 380V	5.8	1.5	4.5	1.5
	H100T40022BX0	3 phase 380V	6.5	2.2	5.6	2.2
F2	H100T40040BX0	3 phase 380V	12.6	4.0	10.5	4.0
	H100T40055BX0	3 phase 380V	16	5.5	14	5.5
F3	H100T40075BX0	3 phase 380V	21	7.5	19	7.5
	H100T40110BX0	3 phase 380V	28	11	26	11
F4	H100T40150BX0	3 phase 380V	36	15	33	15
	H100T40185BX0	3 phase 380V	42	18.5	40	18.5
F5	H100T40220BX0	3 phase 380V	48	22	46	22

NO.2 Main circuit and function card

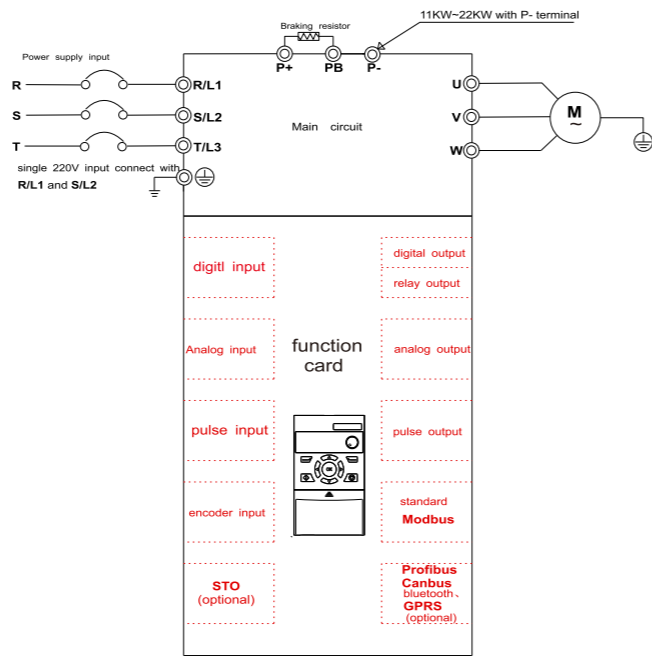

Notice: different function card corresponding to different terminals. Except standard function card, can customize any type of card. Reset parameters when using different function cards. An AC drive only can use one function card.

Warning: Do not use function card when power is on!

2. 1 Main circuit terminal description

Terminal identification	Name	Function description
⊕	Grounding terminal	Safety grounding
R/L1、S/L2、T/L3	Main circuit power input terminal	Connect three phase power supply, single phase power supply connect to R/L1, S/L2
P+、PB	Braking terminal	Connect to external braking resistor
P+、P-	DC bus terminal	Two sets or more inverters use a common DC bus (11KW~22KW has P-terminal)
U、V、W	output terminal	Connect to three phase motor

2.2 Function card configuration table

Function card	H10001	H10002	H10003	H10004	H10005	H10006	H10007	H10008	H10009	H10010	H10011	H10012
Digital Input	4	3	4	8	2	2	3	2	2	4	4	3
Digital output								4	4			
Relay output	1		3	1	1	1	1	1	1	1	1	1
Analog Input	1		1		2			1	1	1	1	1
Analog output					2			1	1			
Pulse input						1						
Pulse output						1						
Encoder Input							1					
Modbus	1	1	1	1	1	1	1	1	1	1	1	1
Profibus								1				
Canbus									1			
Bluetooth										1		
GPRS											1	
STO												1
Typical application												

NO.3 Product Dimension

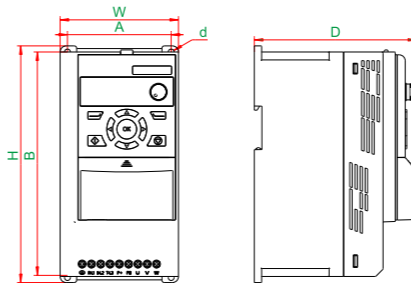

Framework	H1 series Dimensions (mm)					
	W(Width)	H(Height)	D(Depth)	A	B	d
F1	85	170	124	67.3	158	5
F2	97	194	133	85	184	5
F3	126	237	147	112	223	6
F4	168	298	160	154	283	6
F5	198	355	177	183	338	6

NO.4 Keypad description

4. 1 Keypad appearance and keypad explanation

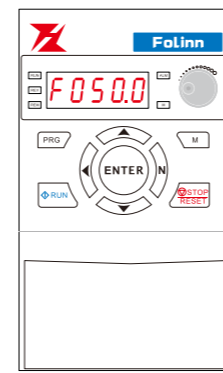

Figure 3-1 H1 series keypad

Item	Structure	Function description
1	Display	Display
2	Program/exit	Program/exit
3	Status display interface work as status switch key; other interface work as left shift key	
4	Reserved key	
5	RUN	
6	Potentiometer	refer to parameter P1.63
7	In the mode of program, work as value change key; otherwise, UP/DOWN key, refer to parameter P1.63, P2.03, P2.04	
9	ENTER	Enter
10	STOP/RESET	STOP/RESET
11	Customization key	

4. 2 Indicator light description

Indicator light	Status	Function description
RUN	light on/ flickering	operating /decelerating
REV	light on	reverse operation
REM	light on	remote operation
ALM	light on	fault indication
M	light on	customization indication, default alarm indication

4. 3 Display item description

Display code	Item description
F	output frequency
C	output current
U	output voltage
d	DC bus voltage
H	display value 1(P10. 98)
t	display value 2(P10. 99)
R	current alarm
E	current fault

NO.5 Function · Parameter Table

Function	Function	Description (setting range)	Factory default																																				
P0.09	Parameter operation	1.parameter initialization, initialize parameters except P1.XX, in normal condition, use mode 1 initialization; 2. initialize all parameters	0																																				
P0.10	Setting(frequency) reference F1	0: keypad 1: multi-speed 2: AI1 3: AI2	0																																				
P0.11	Setting(frequency) reference F2	0: keypad 1: multi-speed 2: AI1 3: AI2 5: communication	0																																				
P0.12	setting relation selection	<p>* principle interpretation: set 0 choose F1 channel setting value; set 1 choose F2 channel setting value; set 2 choose the sum of F1 and F2 channel setting value; set 3 choose the difference of F1 and F2 channel setting value; set 4 choose the product of F1 and F2 channel setting value divide 100; set 5 choose larger value of F1 and F2; set 6 choose smaller value of F1 and F2; set 7 choose average value of F1 and F2; set 8 choose PID control (F1 is setting, F2 is feedback).</p>	0																																				
P0.13	maximum setting value	- 99999.000~99999.000 * principle interpretation: limit setting value range. The unit of setting source is %, the maximum setting value(P0.13) stands for 100%, take maximum setting value as standard.	50.000																																				
P0.14	motor output frequency upper limit	0.000Hz~1000.000Hz interpretation: motor operation frequency upper limit	55.000Hz																																				
P0.15	multi-speed source	<table border="1"> <thead> <tr> <th>S4</th> <th>S3</th> <th>S2</th> <th>valid multi-speed</th> </tr> </thead> <tbody> <tr> <td>0</td> <td>0</td> <td>0</td> <td>multi-speed 0</td> </tr> <tr> <td>0</td> <td>0</td> <td>1</td> <td>multi-speed 1</td> </tr> <tr> <td>0</td> <td>1</td> <td>0</td> <td>multi-speed 2</td> </tr> <tr> <td>0</td> <td>1</td> <td>1</td> <td>multi-speed 3</td> </tr> <tr> <td>1</td> <td>0</td> <td>0</td> <td>multi-speed 4</td> </tr> <tr> <td>1</td> <td>0</td> <td>1</td> <td>multi-speed 5</td> </tr> <tr> <td>1</td> <td>1</td> <td>0</td> <td>multi-speed 6</td> </tr> <tr> <td>1</td> <td>1</td> <td>1</td> <td>multi-speed 7</td> </tr> </tbody> </table> <p>* P0.15: multi-speed source, select to corresponding external terminal, multi-speed refer to P0.16-P0.23. * eg: select S2, S3, S4 as valid external terminal to control multi-speed set P0.15=1110, detailed 8 segment corresponding relationship as above table</p>	S4	S3	S2	valid multi-speed	0	0	0	multi-speed 0	0	0	1	multi-speed 1	0	1	0	multi-speed 2	0	1	1	multi-speed 3	1	0	0	multi-speed 4	1	0	1	multi-speed 5	1	1	0	multi-speed 6	1	1	1	multi-speed 7	0
S4	S3	S2	valid multi-speed																																				
0	0	0	multi-speed 0																																				
0	0	1	multi-speed 1																																				
0	1	0	multi-speed 2																																				
0	1	1	multi-speed 3																																				
1	0	0	multi-speed 4																																				
1	0	1	multi-speed 5																																				
1	1	0	multi-speed 6																																				
1	1	1	multi-speed 7																																				
P0.16	multi-speed 0		0.000%																																				
P0.17	multi-speed 1		0.000%																																				
P0.18	multi-speed 2	- 1000.000%~1000.000%	0.000%																																				
P0.19	multi-speed 3	function: multi-speed setting, corresponding to P0.13 maximum setting percentage	0.000%																																				
P0.20	multi-speed 4		0.000%																																				
P0.21	multi-speed 5		0.000%																																				
P0.22	multi-speed 6		0.000%																																				
P0.23	multi-speed 7		0.000%																																				
P0.24	acceleration time	0.000s~3600.000s * principle interpretation: as figure, acceleration time refer to the time from 0Hz accelerate to P0.13 maximum setting value	*S																																				
P0.25	deceleration time																																						
P0.26	Jog frequency	- 1000.000~1000.000 function: set jog frequency, jog command refer to P0.33	10.000%																																				
P0.30	start command source	0: invalid 1: keypad 2: communication	1																																				
P0.31	reverse start command source	3: S1 4: S2 5: S3 6: S4	0																																				
P0.32	reverse command source	function: select command source(select keypad as command source, then reverse start command, reverse command, jog command, free stop command, safe stop command, pause command all from multi-function key of keypad)	0																																				
P0.33	Jog command source		1																																				
P0.34	stop command source	* reverse start command: setting value reversed, and give a start command * reverse command: setting value reversed. * jog command: jog command. Priority is higher than start command, lower than stop command.	0																																				
P0.35	free stop command source	<table border="1"> <thead> <tr> <th>16</th> <th>15</th> <th>14</th> <th>13</th> <th>12</th> <th>11</th> <th>10</th> <th>9</th> <th>8</th> </tr> </thead> <tbody> <tr> <td>S14</td> <td>S13</td> <td>S12</td> <td>S11</td> <td>S10</td> <td>S9</td> <td>S8</td> <td>S7</td> <td>S6</td> </tr> <tr> <td>7</td> <td>6</td> <td>5</td> <td>4</td> <td>3</td> <td>2</td> <td>1</td> <td>0</td> <td></td> </tr> </tbody> </table>	16	15	14	13	12	11	10	9	8	S14	S13	S12	S11	S10	S9	S8	S7	S6	7	6	5	4	3	2	1	0		0									
16	15	14	13	12	11	10	9	8																															
S14	S13	S12	S11	S10	S9	S8	S7	S6																															
7	6	5	4	3	2	1	0																																
P0.36	reset command source	<table border="1"> <thead> <tr> <th>S5</th> <th>S4</th> <th>S3</th> <th>S2</th> <th>S1</th> <th>communication</th> <th>keypad</th> <th>invalid</th> </tr> </thead> <tbody> <tr> <td></td> <td></td> <td></td> <td></td> <td></td> <td></td> <td></td> <td></td> </tr> </tbody> </table>	S5	S4	S3	S2	S1	communication	keypad	invalid									1																				
S5	S4	S3	S2	S1	communication	keypad	invalid																																

Function code	Function	Description(setting range)	Factory default																																																																																																								
P0.37	S1 type	<p>0:positive logic 1:negative logic 2:rising edge 3:falling edge function: select external terminal trigger type</p> <p>* principle interpretation: 0:positive logic, high level is valid status, low level is invalid status; 1: negative logic, high level is invalid status, low level is valid status; 2: rising edge, rising edge is valid; 3: falling edge, falling edge is valid.</p> <p>*two-line mode 1: the mode is most commonly used two-line mode, enable and direction combined, K1 and K2 control forward/reverse of motor</p> <table border="1"> <thead> <tr> <th>K1</th> <th>K2</th> <th>operation command</th> </tr> </thead> <tbody> <tr> <td>OFF</td> <td>OFF</td> <td>stop</td> </tr> <tr> <td>OFF</td> <td>ON</td> <td>reverse</td> </tr> <tr> <td>ON</td> <td>OFF</td> <td>forward</td> </tr> <tr> <td>ON</td> <td>ON</td> <td>stop</td> </tr> </tbody> </table> <table border="1"> <thead> <tr> <th>parameter no.</th> <th>setting value</th> <th>description</th> </tr> </thead> <tbody> <tr> <td>P0.30</td> <td>3</td> <td>start command source is S1</td> </tr> <tr> <td>P0.31</td> <td>4</td> <td>reverse start command source is S2</td> </tr> <tr> <td>P0.37</td> <td>0</td> <td>S1 type is positive logic</td> </tr> <tr> <td>P0.38</td> <td>0</td> <td>S2 type is negative logic</td> </tr> </tbody> </table>	K1	K2	operation command	OFF	OFF	stop	OFF	ON	reverse	ON	OFF	forward	ON	ON	stop	parameter no.	setting value	description	P0.30	3	start command source is S1	P0.31	4	reverse start command source is S2	P0.37	0	S1 type is positive logic	P0.38	0	S2 type is negative logic	0																																																																										
K1	K2	operation command																																																																																																									
OFF	OFF	stop																																																																																																									
OFF	ON	reverse																																																																																																									
ON	OFF	forward																																																																																																									
ON	ON	stop																																																																																																									
parameter no.	setting value	description																																																																																																									
P0.30	3	start command source is S1																																																																																																									
P0.31	4	reverse start command source is S2																																																																																																									
P0.37	0	S1 type is positive logic																																																																																																									
P0.38	0	S2 type is negative logic																																																																																																									
P0.38	S2 type	<p>*two-line mode 2: enable and direction separated, in this mode K1 is enable terminal, direction is controlled by K2.</p> <table border="1"> <thead> <tr> <th>K1</th> <th>K2</th> <th>operation command</th> </tr> </thead> <tbody> <tr> <td>OFF</td> <td>OFF</td> <td>stop</td> </tr> <tr> <td>OFF</td> <td>ON</td> <td>stop</td> </tr> <tr> <td>ON</td> <td>OFF</td> <td>forward</td> </tr> <tr> <td>ON</td> <td>ON</td> <td>reverse</td> </tr> </tbody> </table> <table border="1"> <thead> <tr> <th>parameter no.</th> <th>setting value</th> <th>description</th> </tr> </thead> <tbody> <tr> <td>P0.30</td> <td>3</td> <td>start command source is S1</td> </tr> <tr> <td>P0.32</td> <td>4</td> <td>reverse command source is S2</td> </tr> <tr> <td>P0.37</td> <td>0</td> <td>S1 type is positive logic</td> </tr> <tr> <td>P0.38</td> <td>0</td> <td>S2 type is positive logic</td> </tr> </tbody> </table> <p>* three line mode 1: this mode define SB2 as enable terminal, operation command is generated by SB1 or SB3, control operation direction at the same time. inverter is running and SB2 is in closed state, terminal SB1 or SB3 generates a rising edge signal to control inverter operation and direction; disconnection SB2 to stop inverter.</p> <table border="1"> <thead> <tr> <th>SB1</th> <th>SB2</th> <th>SB3</th> <th>operation command</th> </tr> </thead> <tbody> <tr> <td>—</td> <td>0</td> <td>—</td> <td>stop</td> </tr> <tr> <td>—</td> <td>1</td> <td>—</td> <td>forward</td> </tr> <tr> <td>—</td> <td>—</td> <td>1</td> <td>reverse</td> </tr> </tbody> </table> <table border="1"> <thead> <tr> <th>parameter no.</th> <th>setting value</th> <th>description</th> </tr> </thead> <tbody> <tr> <td>P0.30</td> <td>3</td> <td>start command source is S1</td> </tr> <tr> <td>P0.31</td> <td>5</td> <td>reverse start command source is S3</td> </tr> <tr> <td>P0.34</td> <td>4</td> <td>stop command source is S2</td> </tr> <tr> <td>P0.37</td> <td>2</td> <td>S1 type is rising edge</td> </tr> <tr> <td>P0.38</td> <td>1</td> <td>S2 type is negative logic</td> </tr> <tr> <td>P0.39</td> <td>2</td> <td>S3 type is rising edge</td> </tr> </tbody> </table> <p>* three line mode 2: this mode define SB2 as enable terminal, operation command is generated by SB1, direction command is controlled by K. inverter is running and SB2 is in closed state, terminal B1 generates a rising edge signal to control inverter operation, K control operation direction; disconnection SB2 to stop inverter.</p> <table border="1"> <thead> <tr> <th>SB1</th> <th>SB2</th> <th>K</th> <th>operation command</th> </tr> </thead> <tbody> <tr> <td>—</td> <td>0</td> <td>—</td> <td>stop</td> </tr> <tr> <td>—</td> <td>1</td> <td>OFF</td> <td>forward</td> </tr> <tr> <td>—</td> <td>1</td> <td>ON</td> <td>reverse</td> </tr> </tbody> </table> <table border="1"> <thead> <tr> <th>parameter no.</th> <th>setting value</th> <th>description</th> </tr> </thead> <tbody> <tr> <td>P0.30</td> <td>3</td> <td>start command source is S1</td> </tr> <tr> <td>P0.32</td> <td>5</td> <td>reverse command source is S3</td> </tr> <tr> <td>P0.34</td> <td>4</td> <td>stop command source is S2</td> </tr> <tr> <td>P0.37</td> <td>2</td> <td>S1 terminal command type is rising edge</td> </tr> <tr> <td>P0.38</td> <td>1</td> <td>S2 terminal command type is negative logic</td> </tr> <tr> <td>P0.39</td> <td>0</td> <td>S3 terminal command type is positive logic</td> </tr> </tbody> </table>	K1	K2	operation command	OFF	OFF	stop	OFF	ON	stop	ON	OFF	forward	ON	ON	reverse	parameter no.	setting value	description	P0.30	3	start command source is S1	P0.32	4	reverse command source is S2	P0.37	0	S1 type is positive logic	P0.38	0	S2 type is positive logic	SB1	SB2	SB3	operation command	—	0	—	stop	—	1	—	forward	—	—	1	reverse	parameter no.	setting value	description	P0.30	3	start command source is S1	P0.31	5	reverse start command source is S3	P0.34	4	stop command source is S2	P0.37	2	S1 type is rising edge	P0.38	1	S2 type is negative logic	P0.39	2	S3 type is rising edge	SB1	SB2	K	operation command	—	0	—	stop	—	1	OFF	forward	—	1	ON	reverse	parameter no.	setting value	description	P0.30	3	start command source is S1	P0.32	5	reverse command source is S3	P0.34	4	stop command source is S2	P0.37	2	S1 terminal command type is rising edge	P0.38	1	S2 terminal command type is negative logic	P0.39	0	S3 terminal command type is positive logic	0
K1	K2	operation command																																																																																																									
OFF	OFF	stop																																																																																																									
OFF	ON	stop																																																																																																									
ON	OFF	forward																																																																																																									
ON	ON	reverse																																																																																																									
parameter no.	setting value	description																																																																																																									
P0.30	3	start command source is S1																																																																																																									
P0.32	4	reverse command source is S2																																																																																																									
P0.37	0	S1 type is positive logic																																																																																																									
P0.38	0	S2 type is positive logic																																																																																																									
SB1	SB2	SB3	operation command																																																																																																								
—	0	—	stop																																																																																																								
—	1	—	forward																																																																																																								
—	—	1	reverse																																																																																																								
parameter no.	setting value	description																																																																																																									
P0.30	3	start command source is S1																																																																																																									
P0.31	5	reverse start command source is S3																																																																																																									
P0.34	4	stop command source is S2																																																																																																									
P0.37	2	S1 type is rising edge																																																																																																									
P0.38	1	S2 type is negative logic																																																																																																									
P0.39	2	S3 type is rising edge																																																																																																									
SB1	SB2	K	operation command																																																																																																								
—	0	—	stop																																																																																																								
—	1	OFF	forward																																																																																																								
—	1	ON	reverse																																																																																																								
parameter no.	setting value	description																																																																																																									
P0.30	3	start command source is S1																																																																																																									
P0.32	5	reverse command source is S3																																																																																																									
P0.34	4	stop command source is S2																																																																																																									
P0.37	2	S1 terminal command type is rising edge																																																																																																									
P0.38	1	S2 terminal command type is negative logic																																																																																																									
P0.39	0	S3 terminal command type is positive logic																																																																																																									
P0.40	Y1 terminal source	<p>0:always 0 1:always 1 2:stopped 3:running 4:alarm 5:alarm 6:reversing 64:STO status 100~9999:high level parameter</p> <p>* principle interpretation: terminal source setting value >100 (address mode), the address is selected parameter no., actual value is decided by current value of selected parameter no. terminal source function description as below:</p> <table border="1"> <thead> <tr> <th>setting value</th> <th>function</th> <th>description</th> </tr> </thead> <tbody> <tr> <td>0</td> <td>always 0</td> <td>Y1 terminal output always 0</td> </tr> <tr> <td>1</td> <td>always 1</td> <td>Y1 terminal output always 1</td> </tr> <tr> <td>2</td> <td>stopped</td> <td>in stopped status Y1 terminal output is 0</td> </tr> <tr> <td>3</td> <td>running</td> <td>in running status Y1 terminal output is 1</td> </tr> <tr> <td>4</td> <td>fault</td> <td>in fault status Y1 terminal output is 1</td> </tr> <tr> <td>5</td> <td>alarm</td> <td>in alarm status Y1 terminal output is 1</td> </tr> <tr> <td>6</td> <td>reversing</td> <td>in reversing status Y1 terminal output is 1</td> </tr> <tr> <td>64</td> <td>STO status</td> <td>in STO status Y1 terminal output is 1</td> </tr> <tr> <td>100~9999</td> <td>high level parameter</td> <td></td> </tr> </tbody> </table>	setting value	function	description	0	always 0	Y1 terminal output always 0	1	always 1	Y1 terminal output always 1	2	stopped	in stopped status Y1 terminal output is 0	3	running	in running status Y1 terminal output is 1	4	fault	in fault status Y1 terminal output is 1	5	alarm	in alarm status Y1 terminal output is 1	6	reversing	in reversing status Y1 terminal output is 1	64	STO status	in STO status Y1 terminal output is 1	100~9999	high level parameter		3																																																																										
setting value	function	description																																																																																																									
0	always 0	Y1 terminal output always 0																																																																																																									
1	always 1	Y1 terminal output always 1																																																																																																									
2	stopped	in stopped status Y1 terminal output is 0																																																																																																									
3	running	in running status Y1 terminal output is 1																																																																																																									
4	fault	in fault status Y1 terminal output is 1																																																																																																									
5	alarm	in alarm status Y1 terminal output is 1																																																																																																									
6	reversing	in reversing status Y1 terminal output is 1																																																																																																									
64	STO status	in STO status Y1 terminal output is 1																																																																																																									
100~9999	high level parameter																																																																																																										

Function code	Function	Description(setting range)	Factory default																																																																								
P0.41	AI1 low side voltage(current)	<p>- 99999.000~99999.000 function: analog input AI1 setting *AI1 low side voltage(current): set the lowest voltage(current) of input signal. *AI1 high side voltage(current): set the highest voltage(current) of input signal.</p>	0.000V(mA)																																																																								
P0.42	AI1 high side voltage(current)	<p>*AI1 low side setting: set corresponding value of low side voltage(current) *AI1 high side setting: set corresponding value of high side voltage(current).</p>	10.000V(mA)																																																																								
P0.43	AI1 low side setting		0.000%																																																																								
P0.44	AI1 high side setting		100.000%																																																																								
P0.45	AO1 signal source	<p>0:always 0 1:always 10V/20mA 2:output frequency 3:motor current 4:output voltage 5:motor torque 6:output power 7:setting frequency 100~9999:high level parameter ** principle interpretation: AO1 signal source function description as below:</p> <table border="1"> <thead> <tr> <th>setting value</th> <th>function</th> <th>description</th> </tr> </thead> <tbody> <tr> <td>0</td> <td>always 0</td> <td>analog AO1 output always 0</td> </tr> <tr> <td>1</td> <td>always 10V/20mA</td> <td>analog AO1 output always 1</td> </tr> <tr> <td>2</td> <td>output frequency</td> <td>analog AO1 output is output frequency</td> </tr> <tr> <td>3</td> <td>motor current</td> <td>analog AO1 output is motor current</td> </tr> <tr> <td>4</td> <td>output voltage</td> <td>analog AO1 output is output voltage</td> </tr> <tr> <td>5</td> <td>motor torque</td> <td>analog AO1 output is motor torque</td> </tr> <tr> <td>6</td> <td>output power</td> <td>analog AO1 output is output power</td> </tr> <tr> <td>7</td> <td>setting frequency</td> <td>analog AO1 output is setting frequency</td> </tr> <tr> <td>100~9999</td> <td>high level parameter</td> <td></td> </tr> </tbody> </table>	setting value	function	description	0	always 0	analog AO1 output always 0	1	always 10V/20mA	analog AO1 output always 1	2	output frequency	analog AO1 output is output frequency	3	motor current	analog AO1 output is motor current	4	output voltage	analog AO1 output is output voltage	5	motor torque	analog AO1 output is motor torque	6	output power	analog AO1 output is output power	7	setting frequency	analog AO1 output is setting frequency	100~9999	high level parameter		2																																										
setting value	function	description																																																																									
0	always 0	analog AO1 output always 0																																																																									
1	always 10V/20mA	analog AO1 output always 1																																																																									
2	output frequency	analog AO1 output is output frequency																																																																									
3	motor current	analog AO1 output is motor current																																																																									
4	output voltage	analog AO1 output is output voltage																																																																									
5	motor torque	analog AO1 output is motor torque																																																																									
6	output power	analog AO1 output is output power																																																																									
7	setting frequency	analog AO1 output is setting frequency																																																																									
100~9999	high level parameter																																																																										
P0.46	AO1 low side setting	<p>- 99999.000~99999.000 * AO1 low side setting: set AO1 source minimum value. * AO1 high side setting: set AO1 source maximum value. * AO1 low side voltage(current): set the lowest voltage(current) of output signal. * AO1 high side voltage(current): set the highest voltage(current) of output signal.</p>	0.000																																																																								
P0.47	AO1 high side setting		50.000																																																																								
P0.48	AO1 low side voltage(current)		0.000V(mA)																																																																								
P0.49	AO1 high side voltage(current)		10.000V(mA)																																																																								
P0.50	PID proportional gain	0.000%~10.000% Determine the adjustment intensity of the whole PID regulator, bigger proportional gain is, bigger adjustment intensity is.	0.010%																																																																								
P0.51	PID integral gain	0.001S~999.000S Determine PID regulator to the integral speed adjustment of the division of PID feedback quantity and given quantity, smaller integral gain is, greater adjustment intensity is.	10.000S																																																																								
P0.52	PID output upper limit	-1000.000~1000.000 PID adjust the output maximum value, if higher than maximum value, then output PID output upper limit, relative to P0.11 maximum setting value percentage.	100.000%																																																																								
P0.53	PID output lower limit	-1000.000~1000.000 PID adjust the output minimum value, if lower than minimum value, then output PID output lower limit, relative to P0.11 maximum setting value percentage.	0.000%																																																																								
P0.54	PID range	0.001~99999.000 set according to actual feedback value, if lower than feedback value, then PID invalid.	100.000																																																																								
P0.55	PID dormancy frequency	0.000~500.000 set dormancy accurate frequency, relative to P0.11 maximum setting value percentage.	0.000%																																																																								
P0.56	PID enter dormancy time	0.000~3600.000 inverter reach enter dormancy time and meet to dormancy time, enter dormancy.	0.000s																																																																								
P0.57	PID wakeup deviation	0.000~100.000 percentage based on setting value.	0.000%																																																																								
P0.58	PID enter wakeup time	0.000~3600.000 inverter reach wakeup deviation and meet to wakeup time, operation again.	0.000s																																																																								
P0.59	PID dormancy action	0:no dormancy; 1:PID stop; 2:decelerate to stop; 3:free stop; 4:pause; 5:operate in lowest frequency PID enter dormancy according to setting dormancy action.	0																																																																								
<p>pressure sensor range:1.6MPa(1MPa~10kg)PIDcontrol parameter</p> <table border="1"> <thead> <tr> <th>parameter</th> <th>parameter name</th> <th>unit</th> <th>description</th> </tr> </thead> <tbody> <tr> <td>P1.03</td> <td> keypad setting source</td> <td>0</td> <td>digital keypad(P2.92)setting</td> </tr> <tr> <td>P2.92</td> <td> keypad setting source</td> <td>10</td> <td>PID-digital keypad set 10kg</td> </tr> <tr> <td>P0.11</td> <td> feedback value</td> <td>2</td> <td>PID-analog AI1 feedback</td> </tr> <tr> <td>P0.12</td> <td> setting relationship selector</td> <td>8</td> <td>PID enable</td> </tr> <tr> <td>P0.44</td> <td> AI1 high side setting</td> <td>16</td> <td>AI1 high side set 16kg (0~10V corresponding to 0~16kg)</td> </tr> <tr> <td>P0.50</td> <td> PID proportional gain</td> <td>0.01%</td> <td>according to field adjustment, same PID intensity greater</td> </tr> <tr> <td>P0.51</td> <td> PID integral gain</td> <td>10s</td> <td>according to field adjustment, same PID intensity greater</td> </tr> <tr> <td>P0.54</td> <td> PID range</td> <td>16</td> <td>PID set feedback range 16kg</td> </tr> <tr> <td>P0.55</td> <td> PID dormancy frequency</td> <td>10%</td> <td>PID dormancy frequency set 5Hz (maximum default setting value 50Hz)</td> </tr> <tr> <td>P0.56</td> <td> PID dormancy time</td> <td>5s</td> <td>PID dormancy time 5s</td> </tr> <tr> <td>P0.57</td> <td> PID wakeup deviation</td> <td>20%</td> <td>PID wakeup deviation 20%</td> </tr> <tr> <td>P0.58</td> <td> PID enter wakeup time</td> <td>10s</td> <td>PID wakeup time 10s</td> </tr> <tr> <td>P0.59</td> <td> PID dormancy action</td> <td>2</td> <td>PID inverter to stop after dormancy, set 0 if stop 1 dormancy</td> </tr> <tr> <td>P1.08</td> <td> keypad value 1 source</td> <td>1090</td> <td>keypad display PID setting pressure</td> </tr> <tr> <td>P1.09</td> <td> keypad value 2 source</td> <td>1091</td> <td>keypad display PID feedback pressure</td> </tr> <tr> <td>P2.03</td> <td> UPI command source</td> <td>1</td> <td>UPI command from keyboard</td> </tr> <tr> <td>P2.04</td> <td> DOWN command source</td> <td>1</td> <td>DOWN command from keyboard</td> </tr> </tbody> </table>				parameter	parameter name	unit	description	P1.03	keypad setting source	0	digital keypad(P2.92)setting	P2.92	keypad setting source	10	PID-digital keypad set 10kg	P0.11	feedback value	2	PID-analog AI1 feedback	P0.12	setting relationship selector	8	PID enable	P0.44	AI1 high side setting	16	AI1 high side set 16kg (0~10V corresponding to 0~16kg)	P0.50	PID proportional gain	0.01%	according to field adjustment, same PID intensity greater	P0.51	PID integral gain	10s	according to field adjustment, same PID intensity greater	P0.54	PID range	16	PID set feedback range 16kg	P0.55	PID dormancy frequency	10%	PID dormancy frequency set 5Hz (maximum default setting value 50Hz)	P0.56	PID dormancy time	5s	PID dormancy time 5s	P0.57	PID wakeup deviation	20%	PID wakeup deviation 20%	P0.58	PID enter wakeup time	10s	PID wakeup time 10s	P0.59	PID dormancy action	2	PID inverter to stop after dormancy, set 0 if stop 1 dormancy	P1.08	keypad value 1 source	1090	keypad display PID setting pressure	P1.09	keypad value 2 source	1091	keypad display PID feedback pressure	P2.03	UPI command source	1	UPI command from keyboard	P2.04	DOWN command source	1	DOWN command from keyboard
parameter	parameter name	unit	description																																																																								
P1.03	keypad setting source	0	digital keypad(P2.92)setting																																																																								
P2.92	keypad setting source	10	PID-digital keypad set 10kg																																																																								
P0.11	feedback value	2	PID-analog AI1 feedback																																																																								
P0.12	setting relationship selector	8	PID enable																																																																								
P0.44	AI1 high side setting	16	AI1 high side set 16kg (0~10V corresponding to 0~16kg)																																																																								
P0.50	PID proportional gain	0.01%	according to field adjustment, same PID intensity greater																																																																								
P0.51	PID integral gain	10s	according to field adjustment, same PID intensity greater																																																																								
P0.54	PID range	16	PID set feedback range 16kg																																																																								
P0.55	PID dormancy frequency	10%	PID dormancy frequency set 5Hz (maximum default setting value 50Hz)																																																																								
P0.56	PID dormancy time	5s	PID dormancy time 5s																																																																								
P0.57	PID wakeup deviation	20%	PID wakeup deviation 20%																																																																								
P0.58	PID enter wakeup time	10s	PID wakeup time 10s																																																																								
P0.59	PID dormancy action	2	PID inverter to stop after dormancy, set 0 if stop 1 dormancy																																																																								
P1.08	keypad value 1 source	1090	keypad display PID setting pressure																																																																								
P1.09	keypad value 2 source	1091	keypad display PID feedback pressure																																																																								
P2.03	UPI command source	1	UPI command from keyboard																																																																								
P2.04	DOWN command source	1	DOWN command from keyboard																																																																								

Function code	Function	Description(setting range)	Factory default
P0.60	startup function	<p>0:start frequency operation 1:speed start 2:DC injection</p> <p>* principle interpretation: 0:no frequency output startup mode, meet to P0.61 startup time setting, P0.62 start frequency start to startup operation. 1:speed start, search rotating motor speed, smooth start without impact from search speed. 2:DC injection, inverter startup by "DC injection before startup" mode.</p>	0
P0.61	startup time	0.000S~60000.000S principle interpretation: when system startup, setting start function work within setting start time.	0.000S
P0.62	start frequency	0.000Hz~100.000Hz principle interpretation: start function finish, if setting frequency bigger than start frequency, system start from start frequency; if setting frequency smaller than start frequency, system start from setting frequency.	0.000Hz
P0.63	DC injection current	0.000%~200.000% function: set magnitude of DC injection current. (set P0.60=2 as DC injection) * principle interpretation: start mode is DC injection, need to set magnitude of DC braking current, 100% corresponding to inverter rated current.	100.000%
P0.64	stop function	<p>units:0:free stop; 1:DC braking; tens:1:accurate stop * principle interpretation: during stop process, stop function starts work when output frequency smaller than stop frequency. accurate stop: stop at any speed motor rotation turns are same, realize consistent repeatability of stop position. To get the best efficiency, deceleration time not to trigger over pressure and over loss rate prevention function as long as possible.</p>	0
P0.65	stop frequency	0.000Hz~1000.000Hz interpretation refer to 0.64	0.000Hz
P0.66	DC braking current	0.000%~150.000% set DC braking current.	100.000%
P0.67	DC braking time	0.000s~1000.000s set DC braking time.	0.000s
P0.68	braking resistor mode	0:invalid 1:valid function: braking resistor braking mode parameter set	1
P0.70	control mode	0:VF 1:vector control 1 function:select motor control algorithm	1
P0.71	carrier frequency	2kHz~16kHz function: set carrier frequency	*kHz
P0.72	motor power	0.000kW~100000.000kW function: set motor parameters	*kW
P0.73	motor voltage	0V~1000V function: set motor parameters	*V
P0.74	motor frequency	1Hz~3000Hz function: set motor parameters	*Hz
P0.75	motor current	0.00A~1000.00A function: set motor parameters	*A
P0.76	motor speed	10rpm~65535rpm function: set motor parameters	*RPM
P0.78	VF curve-F1	0Hz~3000Hz	50Hz
P0.79	VF curve-F2	* principle interpretation: set V/F curve under V/F control mode. When vector control 1 is adopted, set the corresponding frequency points of V/F curve to adjust control characteristics of the corresponding control points.	50Hz
P0.80	VF curve-F3		50Hz
P0.81	VF curve-F4		50Hz
P0.82	VF curve-V0	0V~1000V	0V
P0.83	VF curve-V1	* principle interpretation: set V/F curve under V/F control mode. When vector control 1 is adopted, set the corresponding voltage points of V/F curve to adjust control characteristics of the corresponding control points.	*V
P0.84	VF curve-V2		*V
P0.85	VF curve-V3		*V
P0.86	VF curve-V4		*V
P1.41	local address	0~247 function: set inverter local address	1
P1.42	baud rate	0:2400bps 1:4800bps 2:9600bps 3:19200bps 4:38400bps 5~10:reserved function: Communication port configuration	3

NO.6 Fault code

Fault Code	Protection function	Description
1	protection function	inverter components fault or software fault
4	ground fault	Abnormal resistance to ground, cause electric leakage
5	short circuit to ground	short circuit to ground
6	output short circuit	inverter cut off output when inverter output current is 250% larger than inverter rated current.
7	output over current	inverter cut off output when inverter output current is 200% larger than inverter rated current.
8	DC bus over voltage	inverter cut off output if main circuit DC voltage is higher than 400V(220V motor type) or 800V(380V motor type) when motor decelerates.
9	DC bus low voltage	input voltage decrease, inverter cut off output if main circuit DC voltage too low.
10	inverter over heat	inverter cut off output if cooling fin is over heat.
11	self-learning failure	self-learning parameter wrong or motor abnormal.
13	rectifier over heat	rectifier module over heat.
14	U phase loss	output U phase loss.
15	V phase loss	output V phase loss.
16	W phase loss	output W phase loss.
19	no motor connect	motor lost connection during operation.
20	input phase loss	power input phase loss.
21	inverter over load	inverter cut off output when inverter output current exceed inverter rated level (150% 60S).
22	over torque	motor over torque
24	motor over heat	motor temperature is over heat.
25	motor over load	inverter cut off output when inverter output current exceed motor rated level (150% 60S).
26	current limit	output current exceed setting limit threshold.
63	user fault	user defined fault(P3.08)